

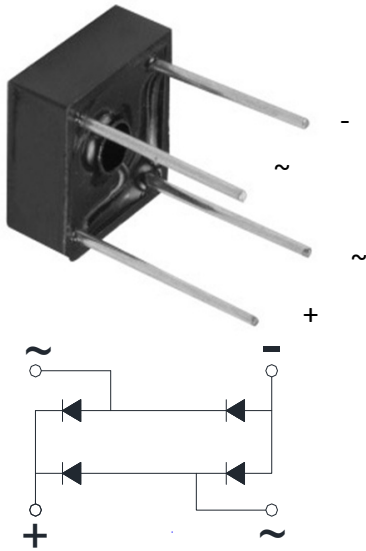

KBPC6005 THRU KBPC610

Bridge Rectifiers



Features

- UL recognition, file #E230084
- Suitable for printed circuit board or chassis mounting
- Compact construction
- High surge current capability
- Solder dip 275 °C max. 7s, per JESD 22-B106

Typical Applications

The KBPC series of single phase rectifier bridge consists of four silicon junctions connected as a full bridge. These devices are intended for general use in industrial and consumer equipment.

Mechanical Data

- **Package:** KBPC6
Molding compound meets UL 94 V-0 flammability rating, RoHS-compliant
- **Terminals:** Tin plated leads, solderable per J-STD-002 and JESD22-B102
- **Polarity:** As marked on body

■ Maximum Ratings ($T_a=25^\circ\text{C}$ Unless otherwise specified)

PARAMETER	SYMBOL	UNIT	KBPC6005	KBPC601	KBPC602	KBPC604	KBPC606	KBPC608	KBPC610
Device marking code			KBPC6005	KBPC601	KBPC602	KBPC604	KBPC606	KBPC608	KBPC610
Repetitive Peak Reverse Voltage	VRRM	V	50	100	200	400	600	800	1000
Average Rectified Output Current @60Hz sine wave, R-load, $T_a=40^\circ\text{C}$	I_O	A	6.0						
Surge(Non-repetitive)Forward Current @60Hz Half- sine Wave, 1 cycle, $T_a=25^\circ\text{C}$	IFSM	A	150						
Current Squared Time @ $1\text{ms}\leq t\leq 8.3\text{ms}$ $T_j=25^\circ\text{C}$, Rating of per diode	I^2t	A^2S	93						
Storage Temperature	T_{stg}	$^\circ\text{C}$	-55 ~+150						
Junction Temperature	T_j	$^\circ\text{C}$	-55 ~+150						

■ Electrical Characteristics ($T_a=25^\circ\text{C}$ Unless otherwise specified)

PARAMETER	SYMBOL	UNIT	TEST CONDITIONS	KBPC6005	KBPC601	KBPC602	KBPC604	KBPC606	KBPC608	KBPC610
Maximum instantaneous forward voltage drop per diode	V _{FM}	V	I _{FM} =3A	1.1						
Maximum DC reverse current at rated DC blocking voltage per diode	I _{RRM}	μA	V _{RM} =V _{RRM}	10						

■ Thermal Characteristics ($T_a=25^\circ\text{C}$ Unless otherwise specified)

PARAMETER	SYMBOL	UNIT	KBPC6005	KBPC601	KBPC602	KBPC604	KBPC606	KBPC608	KBPC610
Thermal Resistance Between junction and ambient	R _{θJ-A}	$^\circ\text{C}/\text{W}$	25						



KBPC6005 THRU KBPC610

■ Ordering Information (Example)

PREFERRED P/N	PACKAGE CODE	UNIT WEIGHT(g)	MINIMUM PACKAGE(pcs)	INNER BOX QUANTITY(pcs)	OUTER CARTON QUANTITY(pcs)	DELIVERY MODE
KBPC6005-KBPC610	A1	Approximate 3.1	200	200	2000	Paper Box

■ Characteristics (Typical)

FIG1:Io-Ta Curve

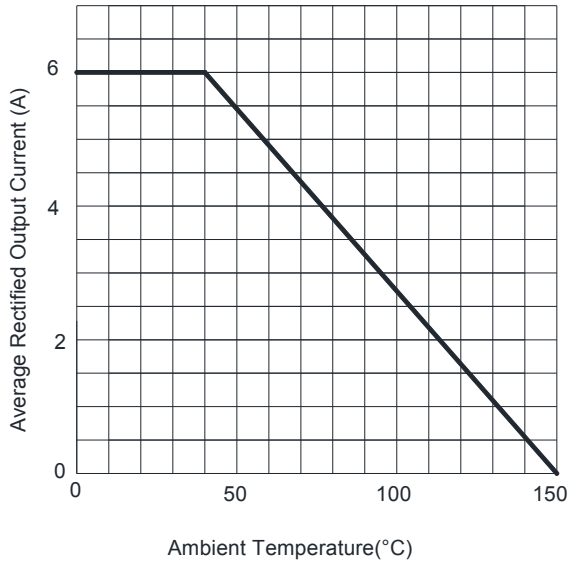

FIG2:Surge Forward Current Capability

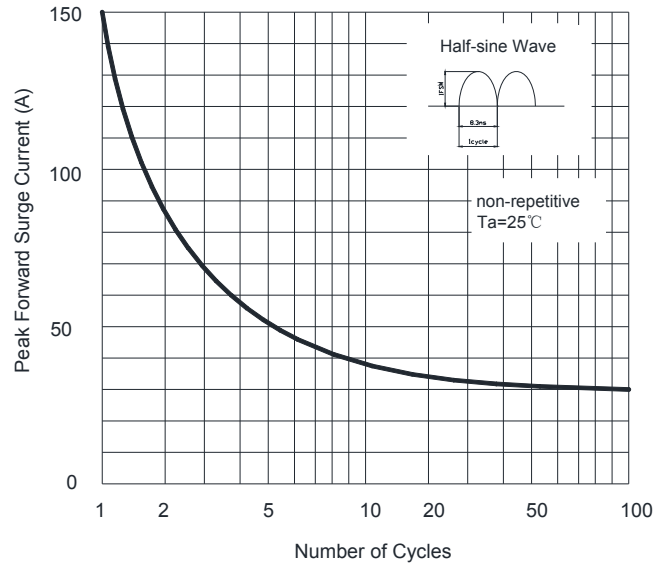

FIG3:Instantaneous Forward Voltage

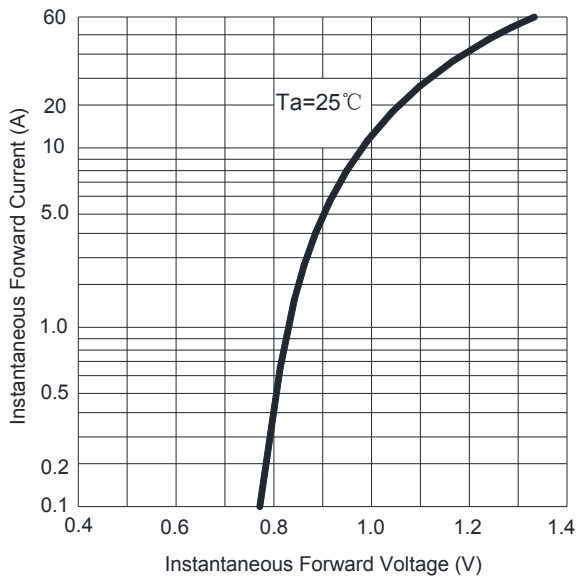
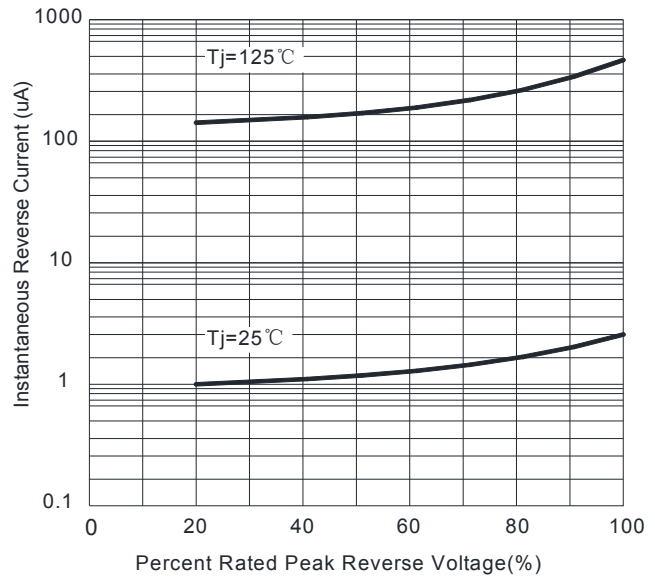

FIG4:Typical Reverse Characteristics





KBPC6005 THRU KBPC610

■ Outline Dimensions

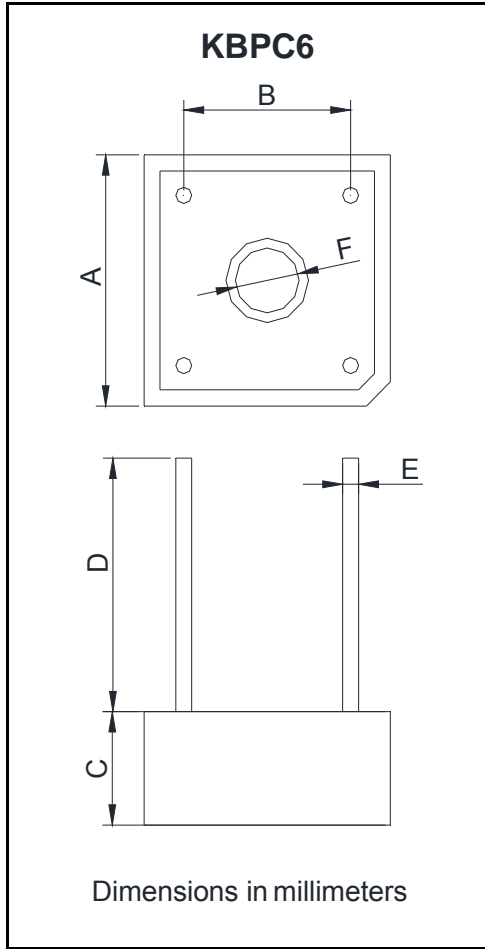

KBPC6		
Dim	Min	Max
A	14.7	15.7
B	10.3	11.3
C	6.35	7.6
D	15.0	/
E	0.95	1.05
F	3.8	4.2