



### 1 Feature

- Ultra-low capacitance:0.05pF(Typ.)
- Low leakage current(<10nA)
- Fast response time(<1ns)
- IEC61000-4-2(Contact) : 8KV  
IEC61000-4-2(Air) : 15KV
- Bi-directional, single line protection

### 3 Application

- Smart phone/Mobile internet device
- Laptop/Desktop computer
- Antennas (Cell Phones, GPS...)
- USB 3.0, USB 3.1 and high speed interface

### 5 Pin Description

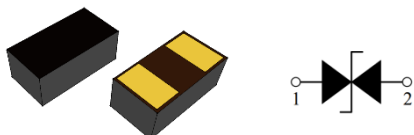

### 2 Description

PESD2463U005 polymeric ESD suppressor help protect sensitive electronic equipment against electrostatic discharge (ESD) without distorting data signals. This protection is a result of its ultra-low capacitance of only 0.05 pF (I/O to GND), and it can be used to help equipment to pass IEC61000-4-2 level 4 test (15KV air, 8KV contact discharge).

### 4 Device Information

Model	Package	Size
PESD2463U005	0603-2	1.60 mm × 0.80 mm × 0.30 mm

### 6 General Characteristics

Parameter	Value	Unit
Contact Discharge Voltage Per IEC61000-4-2	8	KV
Air Discharge Voltage Per IEC61000-4-2	15	KV
Operating Temperature	-55 to +125	°C
Storage Temperature	-40 to +85	°C

### 7 Electrical Characteristics (TA =25°C)

Parameter	Symbol	Conditions	Min.	Typ.	Max.	Units
Continuous Operating Voltage	V <sub>DC</sub>	---	---	---	24	V
Trigger Voltage	V <sub>T</sub>	IEC61000-4-2 8KV contact discharge	---	450	---	V
Clamping Voltage	V <sub>C</sub>	IEC61000-4-2 8KV contact discharge	---	40	---	V
Leakage Current	I <sub>L</sub>	DC 24V shall be applied on component	---	---	10	nA
Capacitance	C <sub>P</sub>	Measured at 10MHz	---	0.05	---	pF
ESD Pulse Withstand	Pulses	IEC61000-4-2 8KV contact discharge	1000	---	---	---

Notes: Trigger and clamping voltage are measured per IEC 61000-4-2, 8KV contact discharge method.

## 8 Typical ESD Response (IEC 61000-4-2, 8KV contact discharge)

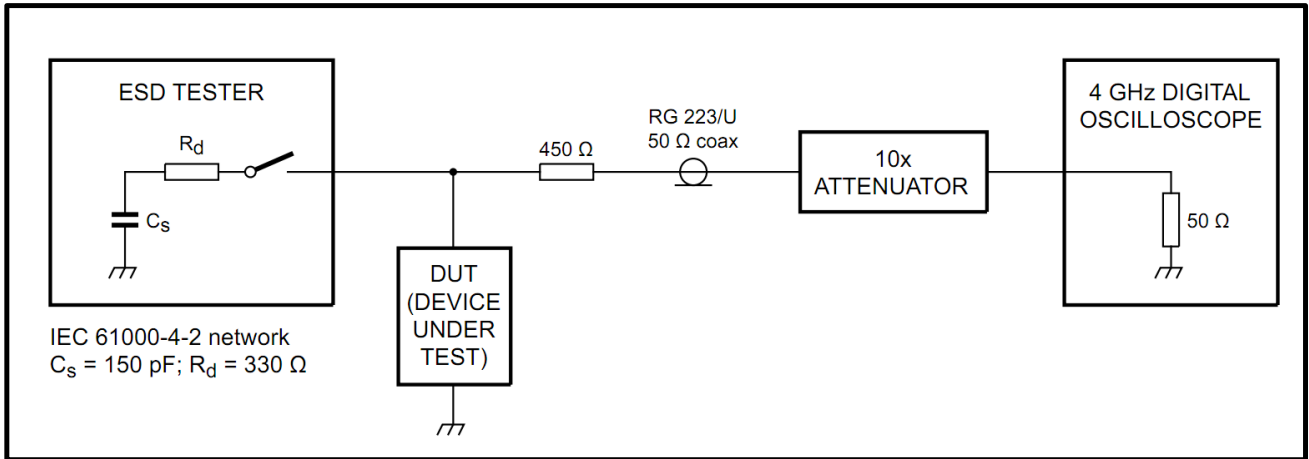

## 9 Typical ESD Response (IEC 61000-4-2, 8KV contact discharge)

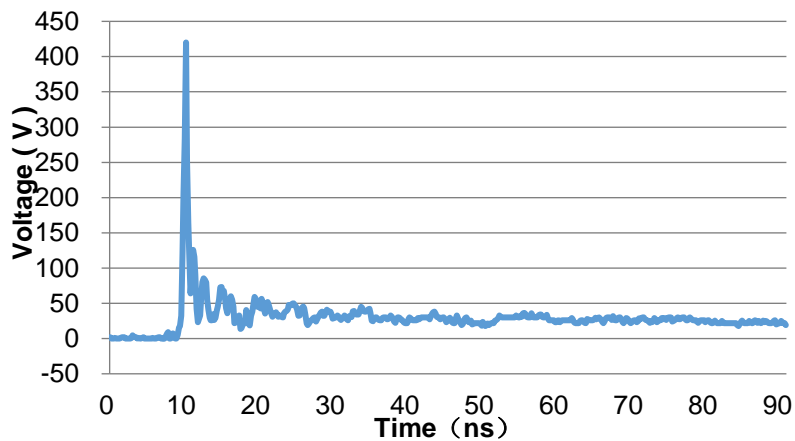

## 10 Typical Device Capacitance VS. Frequency

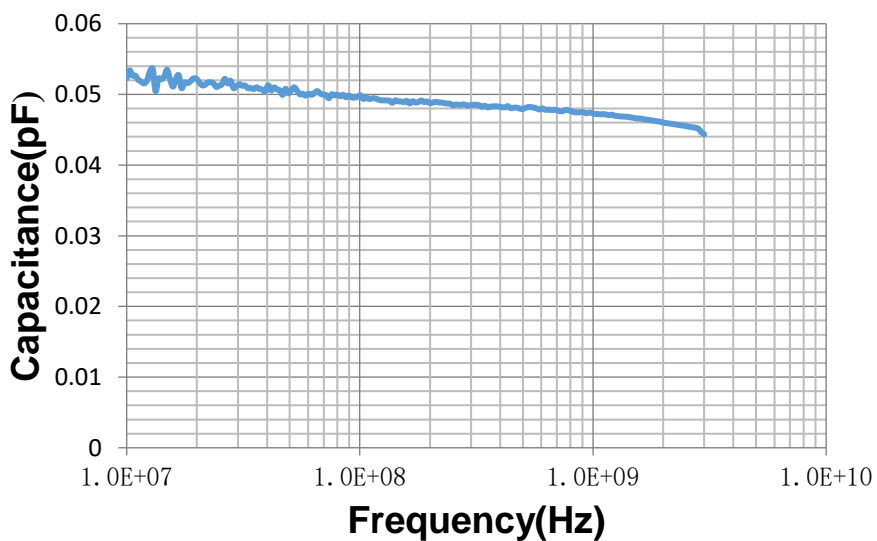

## 11 Eye Diagram Measurement

### HDMI Mask at 3.4 Gbps

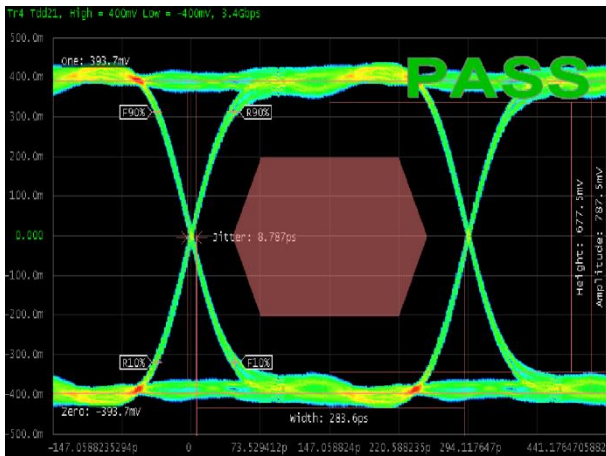

### USB3.0 Mask at 5.0 Gbps

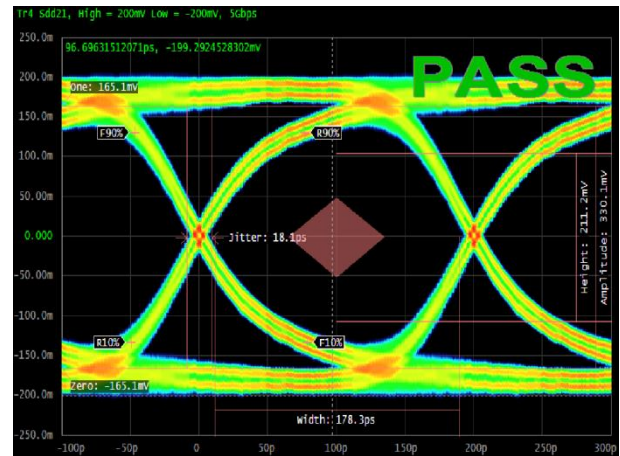

## 12 ESD Protection for Signal Line

The PESD is designed for the protection of one bidirectional data line from ESD damage.

- Place the PESD as close to the input terminal or connector as possible.
- Minimize the path length between the PESD and the protected signal line.
- Use ground planes whenever possible.

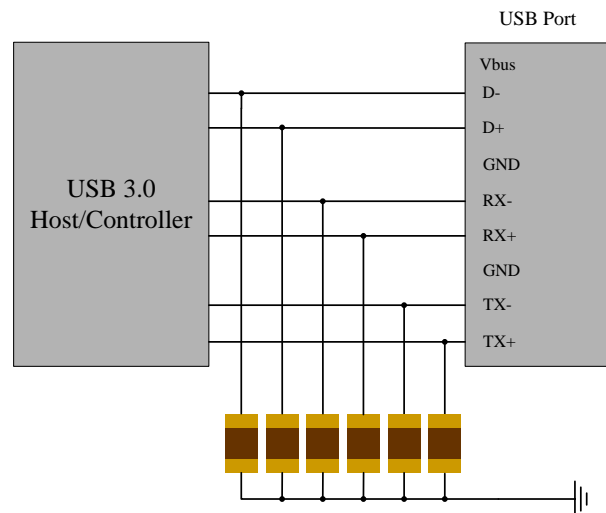
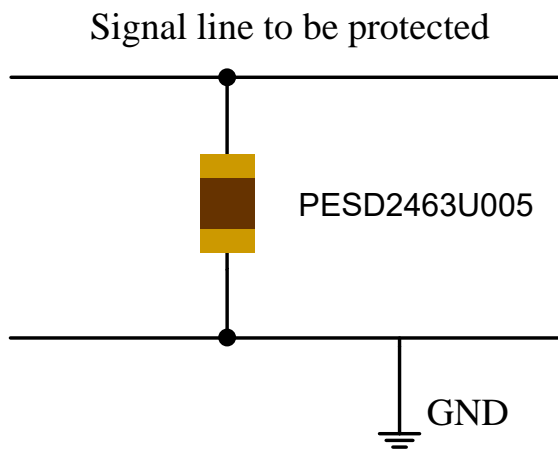

## 12 Soldering Parameters

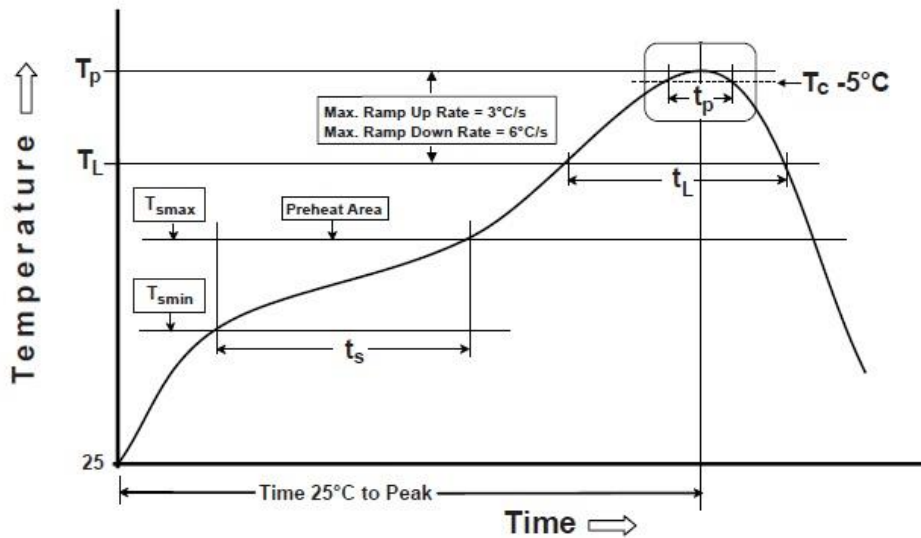

Profile Feature	Pb-Free Assembly
Pre Heat	
Temperature Min ( $T_{smin}$ )	150 °C
Temperature Max ( $T_{smax}$ )	200 °C
Time ( $t_s$ ) from ( $T_{smin}$ to $T_{smax}$ )	60-120 seconds
Ramp-up Rate ( $T_L$ to $T_p$ )	3 °C/second max.
Liquidus temperature ( $T_L$ )	217 °C
Time ( $t_L$ ) maintained above $T_L$	60-150 seconds
Peak package body temperature ( $T_p$ )	260 <sup>+0/-5</sup> °C
Time ( $t_p$ )* within 5 °C of the specified classification temperature ( $T_c$ )	30* seconds
Ramp-down Rate ( $T_p$ to $T_L$ )	6 °C/second max.
Time 25 °C to peak temperature	8 minutes max.
* Tolerance for peak profile temperature ( $T_p$ ) is defined as a supplier minimum and a user maximum.	

## 13 Package Dimension

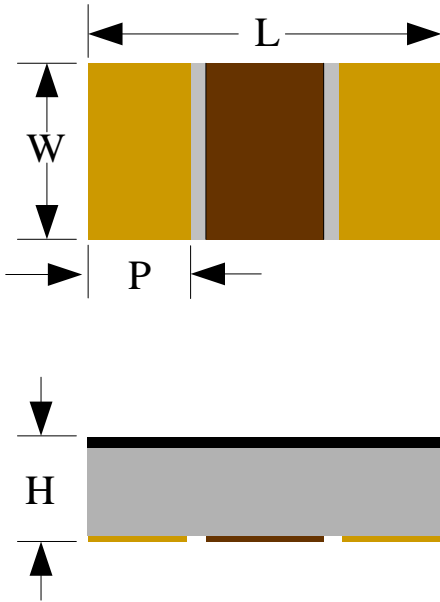

## Recommended Solder Pad Footprint

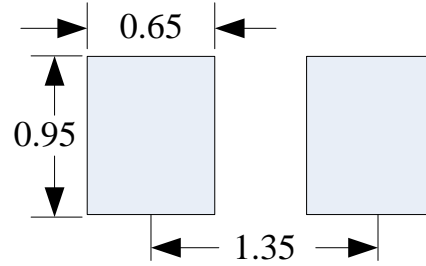

**\*Sizes in mm**

Notes:

This solder pad layout is for reference purposes only.

Dimension	Unit: Millimeters		
	Min.	Typ.	Max.
L	1.45	1.60	1.75
W	0.70	0.83	0.95
P	0.20	0.35	0.50
H	0.26	0.36	0.46

## 14 Taping Specification

Unit: Millimeters

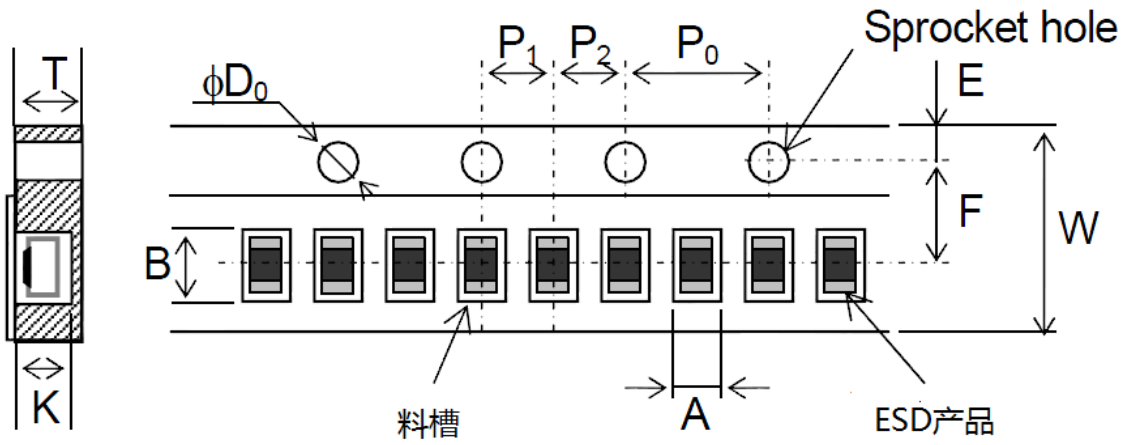

Tape Dimension	A	B	W	F	E	P <sub>1</sub>	P <sub>2</sub>	P <sub>0</sub>	$\phi D_0$	K	T
	1.00±0.03	1.9±0.03	8.00±0.10	3.50±0.05	1.75±0.10	2.00±0.05	2.00±0.05	4.00±0.10	1.55±0.05	0.43±0.03	0.43±0.03

Unit: Millimeters

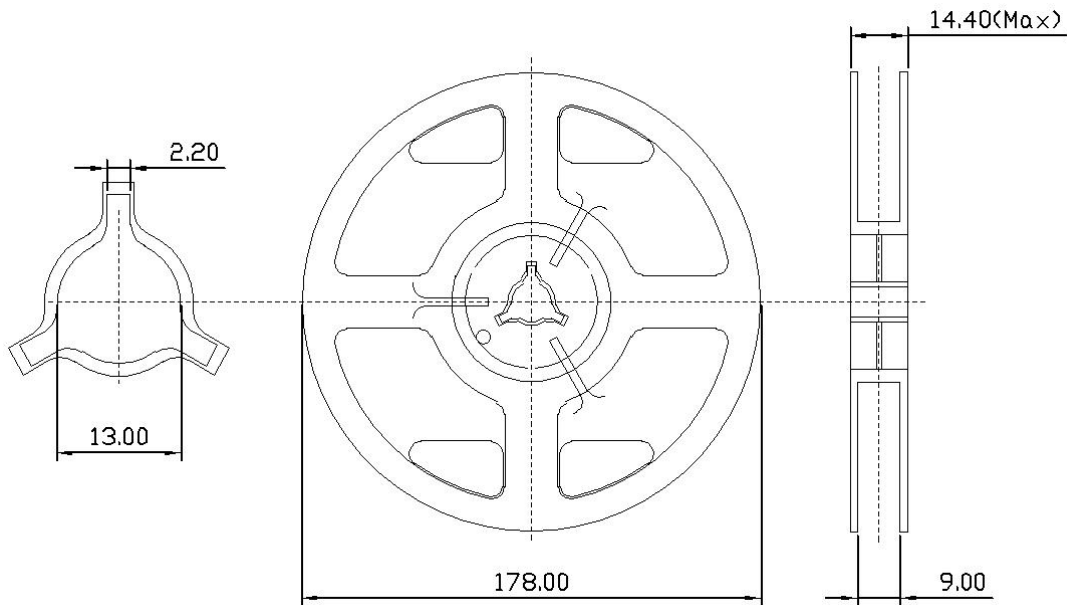



**15 Ordering & Contact Information**

<b>Ordering Code</b>	<b>Package</b>	<b>Net Weight</b>	<b>Delivery Form</b>	<b>Delivery Quantity</b>
PESD2463U005	0603-2	1.0 mg / 1 pce	Mini T&R (7")	5,000 pcs/reel